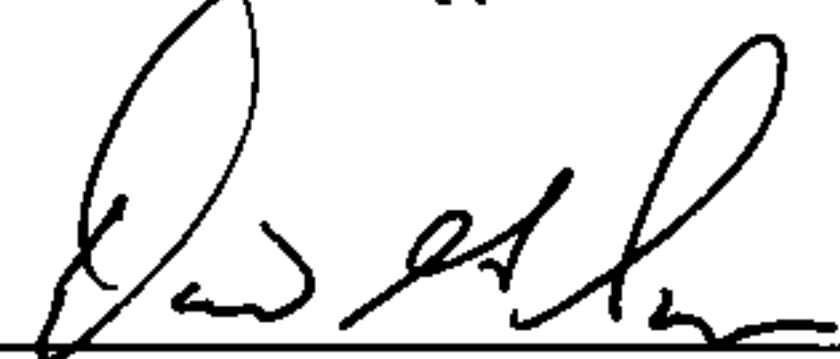
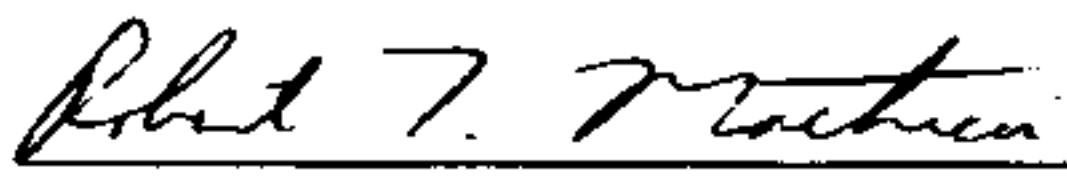

Title: WIYN Cassegrain Instrument Adapter Subsystem

Document Number: WODC 01-⁴³~~4~~-01

Reviewed and Approved:

 /David Sawyer 3/13/98
Site Manager Date

 /Robert Mathieu 3/13/98
Chairman Scientific Advisory Committee Date

 /Bill van Altena 3/13/98
President WIYN Board Date

WODC 01-43-01
 WIYN Cassegrain Instrument Adapter Subsystem (CassIAS) Design Requirements

Table of Contents

1. Purpose & Scope.....	3
2. General Description.....	3
3. Interfaces.....	4
3.1 Wisconsin Reimager/Rotator.....	4
3.2 Modified Cassegrain Focus Characteristics.....	4
3.3 Science Instrument Mechanical Interface.....	5
3.4 CassIAS Control.....	5
3.5 CassIAS Interconnection.....	5
3.6 Thermal Requirements.....	6
4. CassIAS Mechanical.....	6
4.1 Configuration.....	6
4.2 Size and Weight.....	6
4.3 Structural Requirements.....	6
5. Acquisition/Guide Requirements.....	6
5.1 Acquisition/Guide Camera.....	7
5.2 Camera Filter Mechanism.....	7
5.3 X-Y Stage.....	7
5.4 Camera Focus (Z-Stage).....	7
6. Feed Mirror.....	7
6.1 Positioning Requirements.....	8
7. Calibration Source.....	8
8. Atmospheric Dispersion Compensator.....	8
9. Filter Wheel.....	8
10. Electrical.....	8
11. Environmental.....	9
12. Figures.....	9
Figure 1: CassIAS Space Envelope and Mounting Dimensions.....	9
Figure 2: Schematic of Internal CassIAS Components.....	9
Figure 3: Probability of finding guide stars at the modified Cassegrain Port.....	9

WODC 01-43-01 Cassegrain Instrument Adapter Subsystem Design Requirements

1. Purpose & Scope

This document defines the design requirements for a general instrument interface and guider for use at the F/13.5, "modified" Cassegrain focus of the WIYN Telescope, hereinafter referred to as the CassIAS.

2. General Description

The CassIAS will provide a mounting interface for small, lightweight instruments that fit within the space and weight constraints of the modified Cassegrain port.

The CassIAS is to provide the following common functions which are required to utilize scientific instruments at the f/13.7 Cassegrain focus:

- Acquire an observation field
- Acquire guide stars on the edge of the observation field
- Guide on these stars
- Provide instrument spectral calibration sources
- Provide "slit view" capability
- Provide filter wheel for instruments (optional)

Necessary functionalities for which some of the hardware already exist at this focus but which will require integration with this system are:

- Derotation of the image
- Atmospheric dispersion compensation.

It is not anticipated that wavefront aberration measurement will be necessary at this focus.

The CassIAS will consist of an instrument mounting box that attaches to the Cassegrain Reimager previously developed by the University of Wisconsin and provides a rigid mounting surface and modest clearance for scientific instruments. Figure 1 shows some of the constraining dimensions for the mounting box. The CassIAS will contain the following components which are illustrated in figure 2:

- Movable mirror to select the beam "seen" at various stations
- ICCD camera on an x-y-z stage for acquisition, focus and guiding
- Integrating sphere and optics for calibration sources (or a fiber feed from the existing CIA module)
- Pellicle optics for simultaneous viewing of sky and instrument station
- Instrument filter wheel (optional)

The beam selector mirror will be at a 45 degree angle to the f/13.7 optical axis provided by the Wisconsin Reimager and will move perpendicular to that axis. In the central position the mirror will direct the entire beam to an ICCD camera station for purposes of acquisition. In this position the back side of the mirror will direct the beam from the calibration source to science instrument station. Another position will hold configurable beam selector mirrors with holes of TBD sizes to allow the central portion of the beam of the telescope to pass directly through to the science instrument station while an outer annulus of the field (roughly 8 arc-minutes) is directed to the ICCD camera station for purposes of guiding (minimum FOV for DensePak is 2 arc minutes requiring a hole of roughly 30 mm diameter). A third position will allow the entire 8 arc-minute field to pass to the instrument unvignetted. In one other position of the beam selector mirror, pellicle optics including a retro-reflector and reimaging lens will be introduced into the beam so that the sky and science instrument front face can be viewed simultaneously by the a/g camera.

The entire useable F13.7 field of 8 arc-minutes diameter will be available for on-axis acquisition and offset guiding. An x-y motion stage will be incorporated to allow the acquisition/guide (a/g) camera to access the entire field. Due to the steep curvature of field (19cm radius) the field cannot be flattened using lenses and the camera will therefore be focused using a Z-stage motion. A single ICCD camera will be interfaced to the existing imaging processing system (IPS) and TCS for use as the (a/g) camera. Gain control for the a/g camera will be provided using ICCD control electronics currently available for the NIAS guide probes.

Guiding will involve tracking corrections applied to the main telescope mount axes using existing software.

Since only one a/g camera will be provided, closed-loop field rotation guiding is not possible. Therefore, field rotation will be accomplished by means of computation and open loop commanding of the rotator incorporated in the Wisconsin reimager as is currently done for the Wisconsin HPOL instrument.

Space will be reserved for a set of emission line and continuum sources to provide wavelength and flat field calibration of science instruments. This may be part of the original fabrication or deferred for later upgrade. The calibration assembly may consist of an integrating sphere with multiple input ports and associated optics to relay the calibration light to the focal plane. A motorized and encoded filter holder may be needed at the output of the integrating sphere to control intensity and wavelength.

A configurable filter wheel may be needed in the CassIAS because of back focal distance limitations. The minimum back focal distance needed for instruments with internal filters is 50mm.

3. Interfaces

3.1 Wisconsin Reimager/Rotator

The Wisconsin Reimager/Rotator has a 4-bolt pattern on a 16-inch diameter flat plate as shown in figure 1. Cable connections coming from the instruments and CassIAS will be simply draped to the telescope eliminating the need for a cable wrap. Cables will be routed through the elevation axis cable chain and will not restrict telescope motion in any way. No part of the instrument mounting box will protrude across the back plane of the Wisconsin Reimager/Rotator except for the bolts and locating pins.

The mounting box interface to the Wisconsin Reimager/Rotator will be no larger in diameter than the 16-inch back plate of the reimager. Roughly 1 inch below the interface plane the mounting box may be as large as can be accommodated by the 32-inch diameter primary mirror hole access cylinder.

The nominal focus of the telescope is 7.75 inches behind the Wisconsin Reimager/Rotator back plane. The goal of the instrument mounting box is to consume no more than 5.75 inches of this back focal distance and thus provide at least 2 inches of instrument accommodation space.

3.2 Modified Cassegrain Focus Characteristics

The optical characteristics of the WIYN f/13.6 Cassegrain focus are listed on the WIYN web page <http://claret.kpno.noao.edu/wiyn/wiynfacts.html> and are reproduced here for reference.

Eff. Focal Len.	47810.86 mm
Image Space F/#	13.665
Exit Pupil Dia.	88.9 mm
Exit Pupil Pos.	-1227 mm
Back Focal Dis.	485.417 mm
Plate Scale (on axis)	4.314 arc-sec per mm
Magnification	2.173 $f(13.6)/f(6.4)$
Field of View	8 arc minutes (approx. diam.)
Radius of Focal plane	-190.64 mm
Wavelength coverage	panchromatic

Surf	Radius	Thickness	Glass	Diameter	Conic
1	-2000	-517.444	MIRROR	359.0	-3.79155 (-e ²)
2	-354.85	1002.861	MIRROR	100.0	-1.44617
IMA	-190.64	0.0		130.0	0

3.3 Science Instrument Mechanical Interface

Science instruments will be mounted on the instrument mounting box. The bolt pattern will duplicate the inner bolt pattern of the IAS to accommodate sharing of instruments between the two ports. In addition, a bolt circle identical to that on the Wisconsin Reimager will be available. Except for bolts and alignment pins, no part of either the mounting box or the science instrument shall extend across the plane of this interface. Science instrument cables will route across the Wisconsin Reimager/Rotator via the same cable chain as used for the mounting box itself. The CassIAS shall allow science instruments of up to and including the following envelope:

Maximum instrument mass	100 kg
Maximum cantilever moment	500 N-m
Maximum science instrument envelope	80 cm diam x 1.0 m long (including CassIAS)
Maximum imbalance about optical axis	50 N-m
Maximum instrument flexure	20 microns

3.4 CassIAS Control

Control electronics for the following functions will be contained within the CassIAS:

- Serial interface to WIYN control system
- CassIAS processor
- Motion controls for the a/g camera x-y-z stage
- Motion controls for the beam selector feed mirror
- Motion controls for a/g camera and instrument filter wheels
- Electronics for a/g camera and feed mirror position sensors
- Instrument field derotation
- Calibration lamp selection
- ADC control

A control electronics module (CEM) will communicate with the control system via a serial RS485 link using the TCP/IP protocol. The serial link will connect to the TCS where commands and telemetry data are processed. The CEM will interface to all internal CassIAS functions and will receive commands from the TCS for the motion controllers, calibration lamps, and rotator control module (RCM), as will send position and status information for all CassIAS functions to the TCS. For complete control system interface specifications refer to WODC 10-20.

Video from the ICCD camera will be RS170 and will be fed directly to the WIYN Image Processor (IP) input multiplexer. The IP will calculate the centroids of the guide star positions from the ICCD camera output and send the information to the TCS. The TCS will utilize this position data to determine tracking corrections for the azimuth and elevation.

The rotator control module (RCM) will communicate with the control system via serial RS485. The RCM will compute tracking trajectories and provide open-loop motor control for the instrument rotator.

3.5 CassIAS Interconnection

A cabling interface panel will be provided on the CassIAS and will contain the following connections:

Description	Signal/Cable	Connector
-------------	--------------	-----------

Serial communication	RS485	DB15
ICCD gain control	19-cond.	Amphenol 19 pin
Video	RG59 coax	BNC
Video sync	RG59 coax	BNC
Calibration lamp power	TBD	TBD
Calibration lamp control	TBD	TBD
Rotator motor control	TBD	TBD
Rotator position signal	TBD	TBD

Cable connections coming from the instruments and CassIAS will be simply draped to the telescope eliminating the need for a cable wrap. Cables will be routed through the elevation axis cable chain and will not restrict telescope motion in any way

3.6 Thermal Requirements

Heat escaping into the dome, mirror cell, and optical path will be minimized to less than 30 watts by channeling waste heat into the fork tine and ventilating it with other waste heat away from the building.

Components of the CassIAS control that generate heat should be isolated from the optical path in a ventilated chamber. Components that generate excessive levels of heat (such as high voltage calibration lamp control) should be located remotely from the CassIAS in a location where image quality will not be adversely affected.

4. CassIAS Mechanical

4.1 Configuration

Refer to figure 1 which shows a schematic of the CassIAS on the WIYN Telescope and figure 2 which shows a cut-away view of the internal components.

4.2 Size and Weight

The mounting box physical specification envelope is as follows:

Maximum CassIAS mass	30 kg.
Maximum cantilever moment from WRR surface	TBD
Maximum imbalance about the optical axis	120 N-m
Maximum CassIAS envelope	0.5 x 0.5 x 0.146 m

4.3 Structural Requirements

The instrument mounting box will be designed for minimum deflection and hysteresis.

5. Acquisition/Guide Requirements

Guide stars will be accessible over an 8 arc-minute diameter field of view. The camera performance should be as follows:

Minimum detectable magnitude	17 w/ dark sky
Minimum guide magnitude	16
Field of view	0.75 arc minutes
Sensitivity	Centroid to 10% @ mv=16 & 1Hz
Dimension Stability	0.1 arc-sec RMS

The probability of finding guide stars of various magnitudes at various latitudes is show in figure 3. The plot assumes that the field available for guide stars is an annulus of 8 arc-minutes OD and 2 arc-minute ID.

5.1 Acquisition/Guide Camera

The acquisition/guide camera will be an uncooled ICCD. The camera must have sufficient sensitivity to detect c. 17 magnitude. Such a camera already exists for the Nasmyth IAS and will be duplicated for this instrument. The gain control electronics also exist for ICCD cameras and can be shared with NIAS guide cameras.

5.2 Camera Filter Mechanism

The camera of section 5.1 has a light intensifier tube which can permanently damaged by exposure to excessive light. Therefore, a filter slide or wheel shall be provided for color and neutral density filters. Filters similar to those in the existing Nasmyth IAS will be used.

5.3 X-Y Stage

The acquisition/guide camera will require an X-Y stage to access the entire 8 arc-minute field of view, but because of the folding of the beam by the beam selector mirror, it is not necessary for the camera to be removed from that field of view. Target specifications are as follows:

Minimum position accuracy	10 microns or 0.2 arc sec
Repeatability	5 microns
Encoder resolution	2.5 microns
Maximum field traverse time	10 sec
Minimum field coverage	10 arc minutes
Position stability	5 microns

5.4 Camera Focus (Z-Stage)

Due to field curvature, irregularities in filters, and the possibility of slightly different dimensions of science instrument interfaces, focus adjustment of the acquisition/guide camera will be necessary. The camera focus will be remotely adjusted by moving the camera mount (Z-stage) with a small stepper motor. This motion will not be encoded, however, position will be available in steps from the last position.

Total travel	10 mm
Positioning accuracy/repeatability	60 microns.

6. Feed Mirror

The feed mirror will provide beam selection for the a/g camera, the pellicle optics, and the calibration sources. The mirror will be at a 45 degree angle to the f/13.7 optical axis provided by the Wisconsin reimager and will move on a sliding stage perpendicular to that axis. The sliding stage will be motorized with limit switches at the ends of travel and designed for minimum flexure. The feed mirror slide will contain positions for the following purposes:

1. Acquisition/Calibration
2. Guiding
3. Clear Aperture
4. Pellicle optics

The Acquisition/Calibration position will direct the entire 8 arc-minute beam to the a/g camera station for purposes of acquisition. In this position the back side of the mirror will direct the beam from the calibration source to science instrument station.

The Guiding position will provide a slot for insertable beam selector mirrors to be installed. These mirrors will contain holes of TBD sizes to allow the central portion of the beam of the telescope to pass directly through to the science instrument station while an outer annulus of the field (roughly 8 arc-minutes) is

directed to the ICCD camera station for purposes of guiding (minimum FOV for DensePak is 2 arc minutes requiring a hole of roughly 30 mm diameter). An access window will be provided on the CassIAS so that the mirrors can be changed conveniently.

The Clear Aperture position will allow the entire 8 arc-minute field passes to the instrument unvignetted.

The Pellicle Optics position will contain a pellicle, a retro-reflector and reimaging lens (PRL) which will be introduced into the beam so that the sky and science instrument front face can be viewed simultaneously by the a/g camera. This arrangement will be similar to that incorporated in the Indiana Fiber-Feed Head.

6.1 Positioning Requirements

The feed slide will be motor controlled to meet following requirements:

Min. positioning accuracy along optical axis	0.25 mm
Min. Positioning accuracy along slide axis	0.25 mm
Maximum time for re-positioning	10 seconds

7. Calibration Source

Various spectral line and continuum calibration sources will be available to illuminate the calibration integrating sphere. The sources will provide wavelength calibration for science instruments mounted on the CassIAS. A minimum of four lamp positions will be provided for the following sources:

1. Thorium-Argon
2. Copper-Argon
3. Quartz (or similar continuum)
4. TBD

The calibration sources will be mounted in such a way that any combination of sources can illuminate the integrating sphere. Light from the calibration sources may be piped to the integrating sphere from a remote location by optical fiber. A sliding stage moving a calibration mirror and condensing lens in and out of the beam, will direct the integrating sphere calibration light to the center of the instrument focal plane illumination a small field uniformly, diameter of 4 arc-minutes.

8. Atmospheric Dispersion Compensator

The ADC may be installed as part of the CassIAS rotator stage and if installed will not be removable from the light path. The optical design and control requirements are TBD. Provisions for the ADC lenses and motors are available in the existing UW supplied instrument rotator.

9. Filter Wheel

If the CassIAS requirements cannot be achieved while providing a 50mm back focal distance for instruments, a motorized filter wheel will be provided to accommodate the following:

- 4"x4" filters (note, unvignetted field available to Cass instruments will be reduced to 7.2 arc-min)
- (4) filter positions
- Convenient accessibility

10. Electrical

Power, control and data signals from the control computer and power supply will be provided through cables and connectors that connect directly to the instrument mounting box. This cabling will drape from the CassIAS to the back of the mirror cell, routed across the back of the mirror cell, through the elevation

cable chain, through the fork, and through the maypole if necessary. Power used by the instrument mounting box will be minimized and supply voltages will be standard supply voltages listed below.

±15 volts	TBD amps
± 5 volts	TBD amps
+24 volts	TBD amps

All other supply voltages needed will be derived from the standard supplied voltages, if feasible.

11. Environmental

The CassIAS including all its parts will meet specifications under the following operating conditions:

Ambient temperature	0 to 80 degrees F
Humidity	98% non-condensing
Altitude	6838 ft

12. Figures

Figure 1: CassIAS Space Envelope and Mounting Dimensions

Figure 2: Schematic of Internal CassIAS Components

Figure 3: Probability of finding guide stars at the modified Cassegrain Port

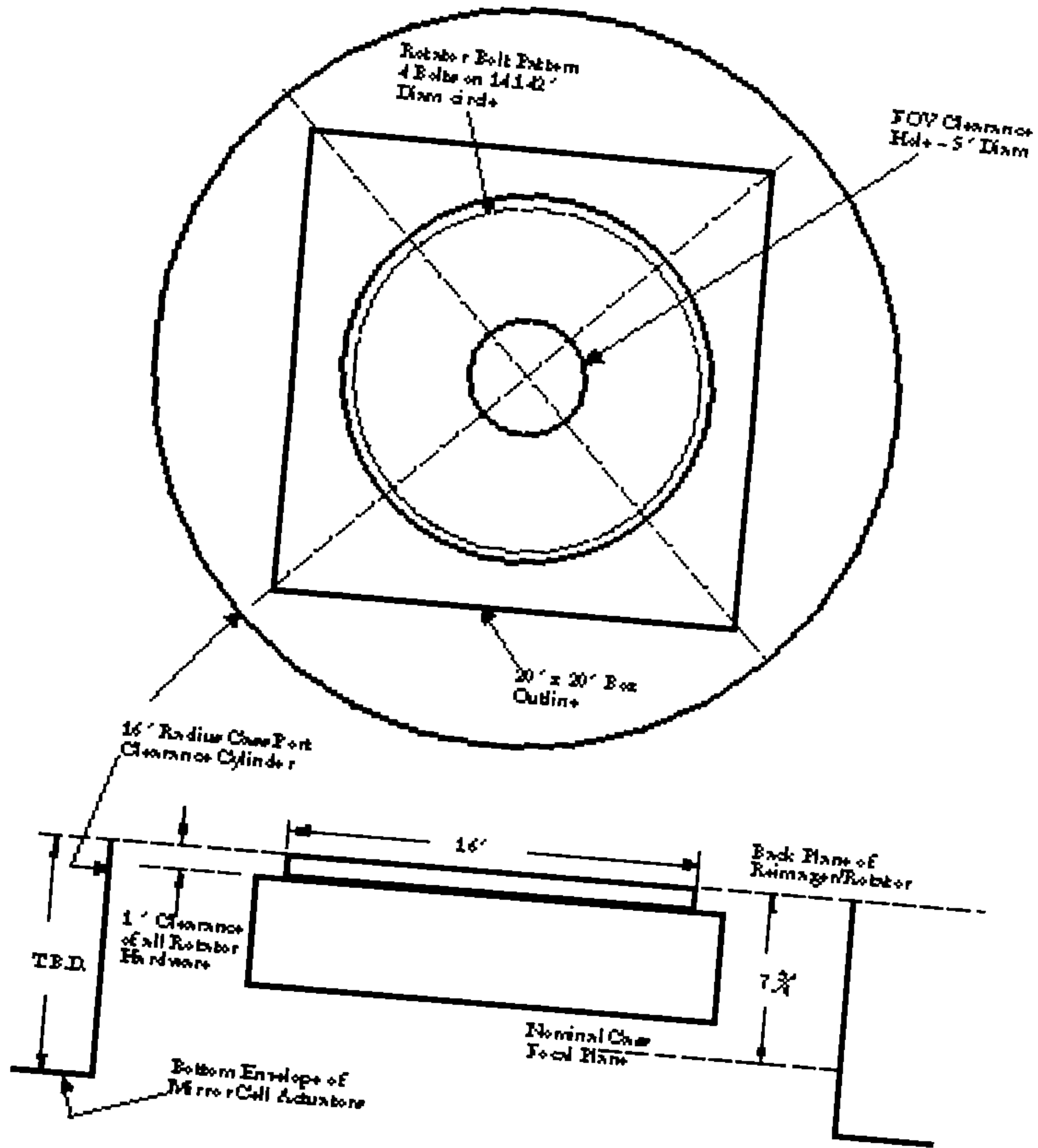

Figure 1: CassIAS Space Envelope and Mounting Dimensions

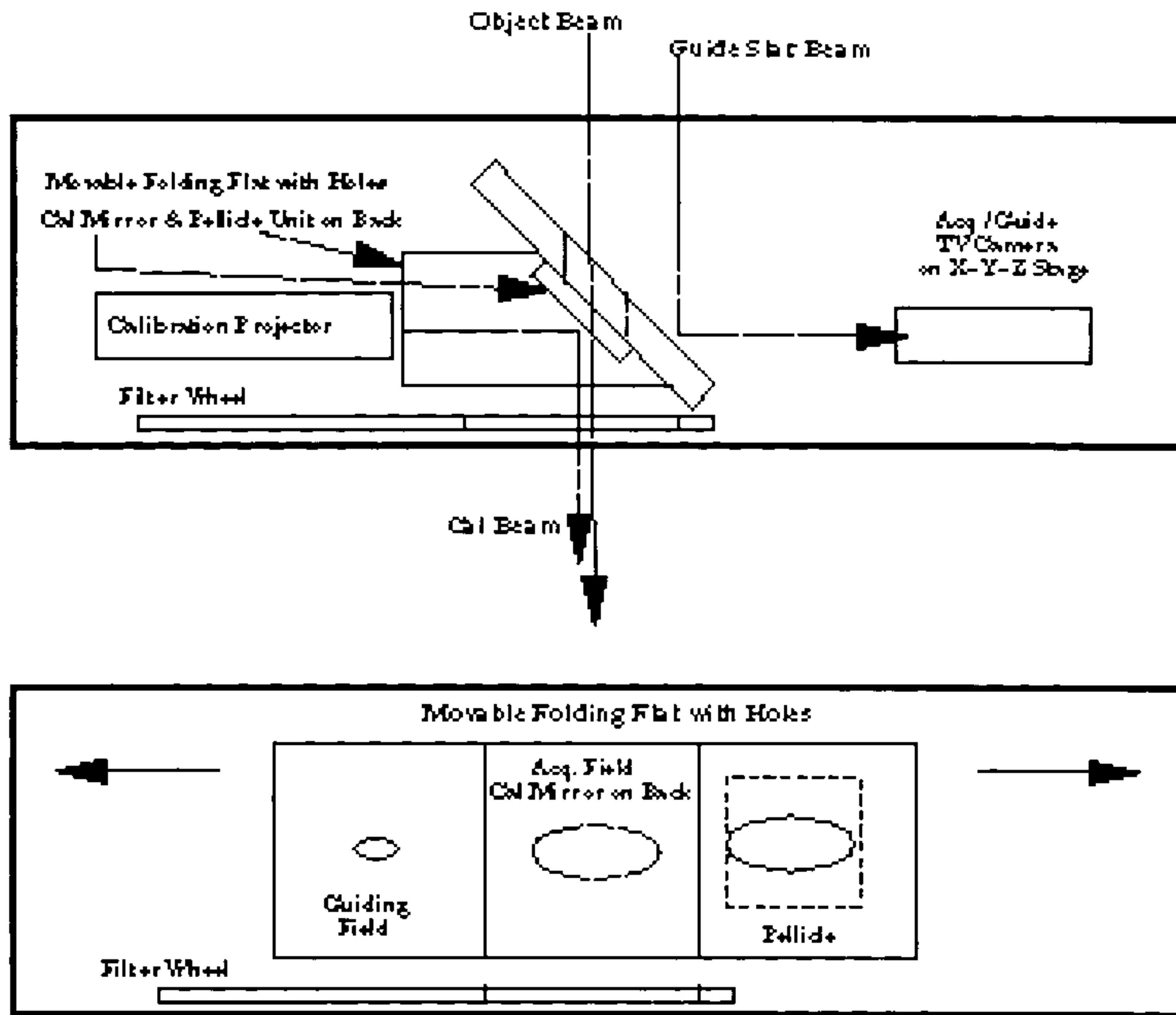

Figure 2: Schematic of Internal CassIAS Components

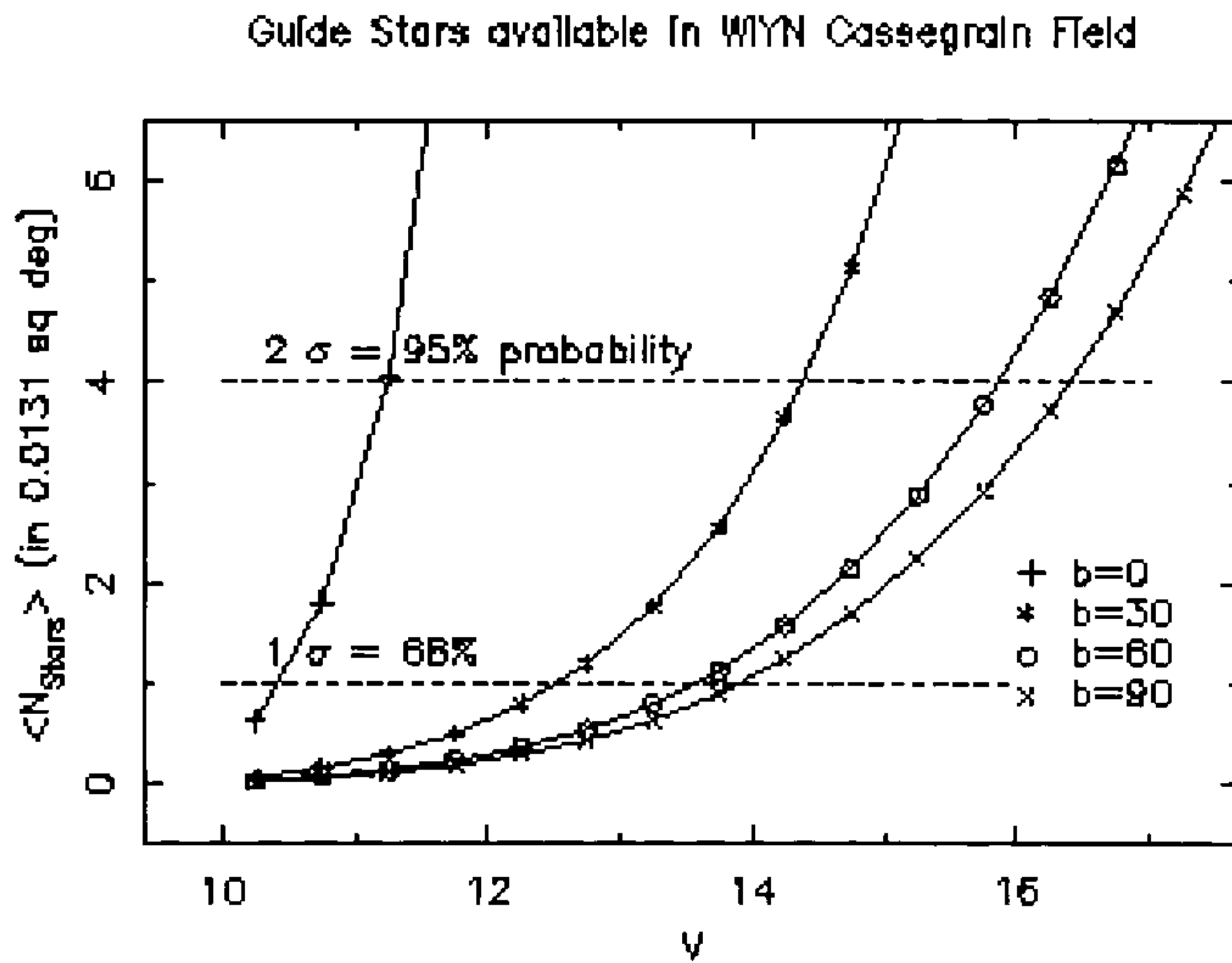

Figure 3: Probability of finding guide stars at the modified Cassegrain Port with a guide field annulus of 8 arc-minutes OD and 2 arc-minutes ID.